

# IS for Decision Support in Usage of Landscapes after Recultivation

M. Nechyba, P. Kotva & J. Zvelebil  
*GEO-TOOLS, Zdiby, Czech Republic*

**ABSTRACT:** The information system (IS) MARE was developed as the system for information and risk evaluation. The system is based on integration of problem-aimed data from monitoring of dynamic processes in hydrology, hydrogeology and hydrochemical status of a landscape and selected geodynamic processes in real time. This system enables to carry out a sensitivity analysis and to evaluate related scenarios as a base for knowledge based decisions about concepts of regional development or, as a base for more effective and more complex evaluation of variants of activities for revitalization or hazard avoiding. The system is being tested on areas of Most and Chabarovice, which are the water-flooded residual pits after open pit mining.

*Keywords: Information system, Decision support system, Data mining, Multi-criterial analysis, Complex system, Fuzzy logic*

## 1 INTRODUCTION

In the last century, there were extensive changes done the landscape in the areas of the testing Brown coal mining in two steps there. Groundwater level was lowered by deep mining in the first step. The open pit mining as the second step was followed by partial filling in of the residual pits by dumps and/or flooding of the pits by water creating artificial lake at the end. Thus, a brownfield environment was created, which structure changes significantly in time and space, changing the conditions for possible various utilization due to this. Accountable decisions about next exploitation of these landscapes and areas ask for complex information based on multidiscipline approach. It is the only way how to take into account all the possible risks, which could limit the intended development.

Most processes, we can observe in the nature, are of very complex structure. The same could be said also about problems connected with geological processes. In this article we will focus our effort only on processes, which occur in areas revitalised by usage of hydric method, namely on evaluation of geotechnical risks, that are connected with this method.

In the era of automatic monitoring and automatic information systems, there is a possibility to use information management for to gain and evaluate data by automatised equipment. This same equipment can also be used for evaluation of these data, which could further be used for to support decision making about necessity of preventive actions in order to avoid damaging of property (this could be such a case, when the local authority has to care about a part of real estate, which could be endangered by risks in a area revitalised on previously exploited mines).

But, then we have to create mathematic model, which could describe the reality as much as possible. As known, the processes in the nature cannot be described by simple functions or formulas. In opposite, the processes are very complex and, it is not easy to describe them in a full scope. Thus, we have to use method, which enables to work out data of different nature, i.e. both qualitative and quantitative values.

## 2 MULTI-CRITERIAL APPROACH

When making a multi-criterial evaluation of risks, a method should be used, which allows to evaluate the total value of risk connected with the landscape and its future exploitation. For to be able to calculate such clearly de-fined risk values for each locality, it was necessary to propose the system of finite steps (methodology), which enables, after certain exactly defined steps, to calculate or to estimate the crisp risk value for the landscape. It the same time, it has to inform us about uncertainty or plausibility of this value for decisions in the future.

For this reason, it was necessary to propose an integrated method, which incorporates both the classical deterministic approach and the approach known from theory of complex systems. It was also necessary to consider the fact, that we don't have all the data necessary, in requested time or spatial density. That's why it was necessary to combine classical mathematic or statistic methods for evaluation of time series together with tools, which enable to transform unmeasurable or estimated or even approximatively factors into numerical model with the goal to evaluate and predict features of the system after extreme change of conditions for some of its input parameter.

This methodology have been integrated into Information System MARE, which is system for decision support in usage of landscapes after re-cultivation. IS MARE was developed as the system for information and risk evaluation. The system is based on integration of problem-aimed data from monitoring of dynamic processes in hydrology, hydrogeology and hydrochemical status of a landscape and selected geodynamic processes in real time. This system enables to carry out a sensitivity analysis and to evaluate related scenarios as a base for knowledge based decisions about concepts of regional development or, as a base for more effective and more complex evaluation of variants of activities for revitalization or hazard avoiding.

For to be able to evaluate a definite size of risk for each site, it was necessary to create a comprehensive procedure (method). It must be able to calculate a clear value of risk in the site after some exactly defined steps and, it must be able to evaluate the plausibility of this value for future decisions. It has to be noted, there are not exactly measured values available for some factors, with requested frequency or in real time.

## 3 METHODS

For to be able to evaluate a definite height of risk for each site, it was necessary to create a comprehensive procedure (method). It must be able to calculate a clear value of risk in the site after some exactly defined steps and, it must be able to evaluate the plausibility of this value for future decisions. It has to be noted, there are not exactly measured values available for some factors, with requested frequency or in real time.

### 3.1 *Covering of the area by system of cells*

In this case, we have covered the part of researched landscape by a mesh of cells. Such a mesh should cover all the important points of the site, i.e. old landslides, old environmental problems, area of interest for investors etc.

### 3.2 *List of factors involved in the process*

In this step, we create a list of factors, which could be involved in the process we describe. In the application MARE we suppose, that for example following factors could occur: Underground water, fast temperature changes, dump, mining bed, landslides, type of soil, tidal forces, terrain profile, factor of stability, abrasion of lake or river banks, saturation of soils by water, industrial factors, rainfall and microclimate, subjective evaluation, contamination of water by metals from dumps, eutrophication, nutrients from dumps and coal seams, abrasion of banks, stability of slopes, setting down, firing-up of seams, amount of rains, partial pressure in pores, level of surface water, air temperature, soil temperature, pH and Eh of water, mechanical stress, 3D movements of soils and undergrounds etc.

### 3.3 *Coincidence matrix*

While the geological process takes place, there are more factors, which can have influence on the process. But, these factors do not act on the principle „each with all others, one by one“. In other words, the coin-

coincidence matrix of these factors is not full. Even more, because relations between some factors cannot be equivalent in both directions (for example, the rainfall can have influence on stability of a slope but, the rainfall cannot be influenced by stability, etc.), the coincidence matrix will not be symmetric.

In order to inactivate not-used relations between factors (better said, between pairs of factors), which cannot not be in any relation, we create and fill-in a coincidence matrix of these factors, where we describe, whether there is (could be) any relation (not known yet) between certain pairs of factors.

### 3.4 *Calculating by Saaty's matrix*

Having selected totally N factors, we should create a matrix  $N \times N$ . In each cell of the matrix, there should be described (by numbers) the relation „The importance of factor X against factor Y“. There could be used more methods known from economy or statistics, so we suppose to use Saaty's matrix („SM“) because of its simplicity. The cells of the SM have to be filled in by numbers, which are the ratios saying how much times (we suppose) the factor X is more (or lesser) important in comparison with factor Y.

When some factor has not been involved in the process, then we have to take out its line and column from the matrix (the SM cannot work with zero values). The SM should be created for more scenarios that could come into reality. These scenarios should cover foreseen possible (real) combinations of input conditions, which can occur. In this way, it is possible to be prepared for more hazardous situations in advance. The automatic system for decision support must have access to actual data and, after their evaluation, it must be able to switch over to other scenario, when it finds out an extreme change of input conditions. In such a case, the SM must be re-calibrated (automatically or manually) in order to be in accordance with reality again.

As said above, it is important to work out such scenarios, which calculate with extreme changes on inputs, i.e. when the stability of the system changes. Let us call them „critical scenarios“(CS). The CS should cover all the spectrum of possible hazardous situations, such as „heavy rain + soil soaked by water + inconvenient slope + ... etc.“.

### 3.5 *Calculating of the factor's participant in the process*

It is necessary to know the intensity of each factor inside the given process. We have to operate with factors of different types and with different scopes of intensity. Even the way of description differs from factor to factor.

One of the method for comparing of such phenomenon is the Multi-Criterion Analyse („MCA“). When using this method, we have to gain two different values of each factor, which we call factor's value („FV“) and uncertainty („UN“).

For this reason, we have programmed a number of small applications, which make possible to evaluate FV of each factor and its subfactors in the process. This calculation has been based on „penalisation points“ - the worse the subfactor for process is, the more penalty points it gets. The limits for FV are 0 and 10 points.

The next characteristic (UN) describes the way we have got the data. Roughly said, the more precise the method for data acquire, the lower the UN, and vice versa. The evaluation begins on 100% for the data obtained by direct measurement by instruments etc., then we have 80% for data calculated by interpolation, 60% for data indirectly calculated from other phenomenon etc., until 30% for data given by expert's opinion.

### 3.6 *Ranges for evaluation of the factor's participant*

Based on the fact, we work with dynamic a complex system, it is necessary to respect dynamical character of some factors in their mutual combination(s), which in the reality can lead to extreme scenarios.

These extreme scenarios can the whole system make unstable, which can cause for example important surface erosion, activation of landslides etc.

For to be able to work out data of different nature, we use fuzzy logic. So it is possible to incorporate different kinds of factors into evaluation, even with different types of ranges. Thus, we can calculate for example with influence of rainfall, temperatures, grain of the soil, abrasion of lake banks, covering by vegetation, evaporation, grade of slope, tidal forces etc. all together.

For this steps, we have to set up bottom and upper limit and to create a scale used for description of actual intensity of each factor. This description should cover all the possible states of the factor we can meet. Let us explain this on following examples.

<b>Name of the factor A:</b>	<b>Air temperature</b>
Lower limit	< -20 °C
Range - interval 1	-20 °C ... 0 °C
Range - interval 2	0 °C ... +5 °C
etc.	...
Range - interval N-2	+10 °C ... +25 °C
Range - interval N-1	+25 °C ... +40 °C
Upper limit $N_A$	> 40 °C
<b>Name of the factor B:</b>	<b>Covering by vegetation</b>
Lower limit:	None
Range - interval 1	very poor, only small areas
Range - interval 2	sporadic areas, not connected
etc.	...
Range - interval N-2	continuous covering
Range - interval N-1	very strong and dense covering
Upper limit $N_B$	full covering
<b>Name of the factor C:</b>	<b>Underground water niveau</b>
Lower limit:	Deeper than 20 m
Range - interval 1	from -20 to -15 m
Range - interval 2	from -15 to -10 m
etc.	...
Range - interval N-2	from -10 to -5 m
Range - interval N-1	from -5 to -2 m
Upper limit $N_C$	from -2 to -1 m

Figure 1. Example of ranges for evaluation

In order to enable calculating with fuzzy sets, we also have to following necessary steps:

- Normalization of intervals in each factor, it means, that the whole range of factor's values has to be transformed into an interval from 0,0 up to 1,0. This can be easily done by usage of linear interpolation. Choosing of fuzzy functions for calculation of „Degree of Membership  $\mu(x)$  (DOM)”. It means, we have to choose the formulas used for calculation of DOM. The value DOM denotes the degrees of membership  $\mu_i(x)$ ,  $\mu_{i+1}(x)$  ... in each fuzzy set  $F_i$ ,  $F_{i+1}$ , ... for the input  $x$ . The simplest function for to describe the fuzzy is the linear one, thus the sets have the triangular shape. It is the mostly used function, although also other shapes could be used (Gaussian, exponential or sigmoid curves etc.). In the Fig.2, we can see an example of a factor, described by triangular (i.e. linear) fuzzy sets.

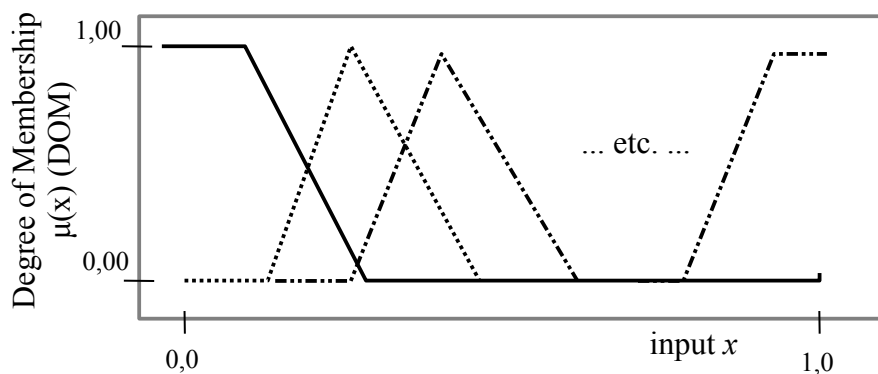

Figure 2. Example of a factor, described by triangular fuzzy sets

- Let us suppose, the measured input value  $x$  is 0.55, thus the degrees of membership  $\mu_i(x)$ ,  $\mu_{i+1}(x)$  ... must be calculated for those fuzzy sets, where the  $DOM > 0$ , as we can see in the Fig. 3. For help, the arrows in the picture can be followed.

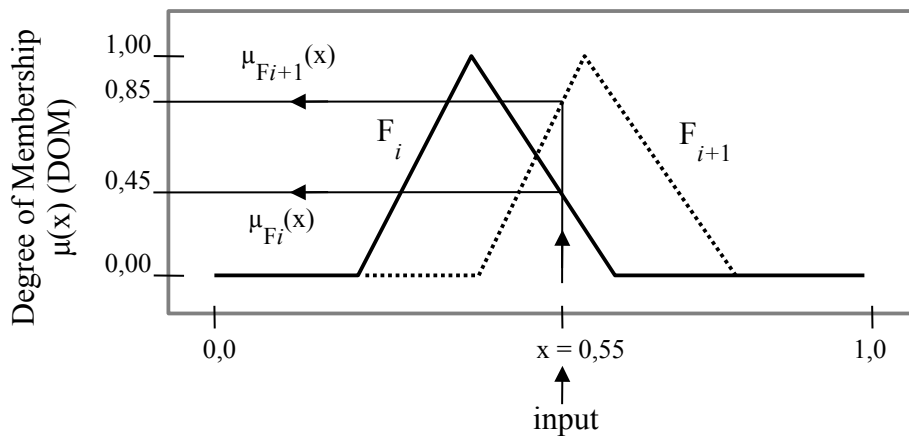

Figure 3. Example of fuzzy sets and degrees of membership

### 3.7 Creating of rules (scenarios) for the role of each factor

As said above, the system must be able to work with different scenarios, which could be expected in the reality. Theoretically, the number of possible scenarios is not limited. But practically, only those scenarios should be thought, which we can supposed to be extreme ones. There is a simple method, which can be used for creation of all possible scenarios - Venn's diagrams (VD).

In following example), we suppose there are 2 critical factors (they are critical because of their dynamic changes or influences), which can lead to extreme scenarios. In order to create all the possible combinations of influences, we use the method based on Venn's diagrams. This method allows to combine different intensities (i.e. intervals) of factors from different points of view, as discussed later.

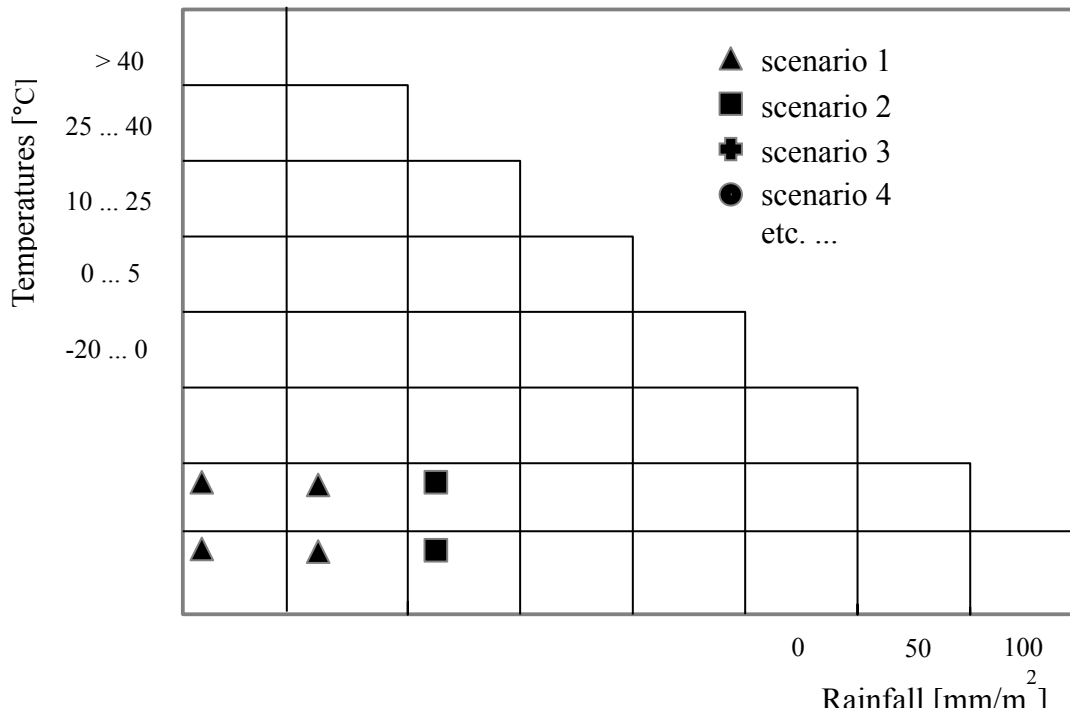

Figure 4. Venn's diagrams for combination of factors „Temperature / Rainfall“

Having the Venn's diagram filled in, we get a graphical overview of intervals in factors, we have to combine in order to cover all possible hazardous situations. This method allows to omit such intervals, which seem to be lesser important for the resulting hazardous situations.

It means, we have to create rules  $R_i$  known from fuzzy logic, based on antecedents and consequents in accordance with the principle „what happens if ...“. The antecedent can include one or more factors (i.e. their values  $A_i, B_j$  ... calculated in previous step) connected by the operator „AND“. The consequent describes the resulting risk calculated from this rule (scenario)  $R_i$ .

An example:

$R_i = \text{IF: (factor A is } A_i) \text{ AND (factor B is } B_j) \text{ AND...}$   
 $\text{... AND (factor K is } K_m) \text{ THEN (the risk Z is } Z_s)$

The number of scenarios has no limit.

Using the symbol  $\mu(x)$  for the DOM, the previous formula can be expressed as follows:

$R_i = \text{IF: } (\mu_{A_i}(x) = A_i) \text{ AND } (\mu_{B_j}(x) = \text{is } B_j) \text{ AND...}$   
 $\text{... AND } (\mu_{K_i}(x) = \text{is } K_m) \text{ THEN } (\mu_{Z_i}(x) = \text{is } Z_s)$

The meaning of the symbol  $\mu_A(x)$  is „for the measured value (x) of the factor A, the factor A is a member of the fuzzy set with the degree of membership equal to  $\mu(x)$ “.

The function „AND“ is the one known from classic binary sets. Using this notation, each rule  $R_i$  can be expressed in following way:

$$R_i = \mu_{Z_i}(x) = \mu_{A_i}(x) \text{ AND } \mu_{B_i}(x) \text{ AND } \dots \text{ AND } \mu_{K_i}(x) = \text{MIN}(\mu_{A_i}(x), \mu_{B_i}(x), \dots, \mu_{K_i}(x)),$$

where the function  $\text{MIN}(x)$  means „minimum from all the values in the brackets at the point (x)“.

After obtaining results  $Z_i$  of each rule  $R_i$ , we have to aggregate (combine) them into a final fuzzy set  $Z$ , which we can describe as „the fuzzy set of the final risk“. For this aggregation, we have to use the function „OR“, known again from the classic set theory. Based on this fact, we can write following formula:

$$\mu_{Z_i}(x) = \mu_{Z_1}(x) \text{ OR } \mu_{Z_2}(x) \text{ OR } \dots \text{ OR } \mu_{Z_S}(x) = \text{MAX}(\mu_{Z_1}(x), \mu_{Z_2}(x), \dots, \mu_{Z_S}(x)).$$

where the function  $\text{MAX}(x)$  means „maximum from all the values in the brackets at the point (x)“.

Because the graphic expression of this set is not simple, there are more methods for to evaluate its shape (we can also speak about de-fuzzyfication) - one of them is „Centre of Gravity“ (COG), which is based on calculation of coordinates of the gravity centre of the boundary shape of the fuzzy set. This coordinate is the number, which describes the value of risk, we want to know.

For not to forget to incorporate any important scenario, we can use following scheme, where we can see all the possibly realised scenarios. It means we draw different (possible or expected) ways between different scales of factors. The different ways (rules, scenarios) have been traced by lines of certain shape.

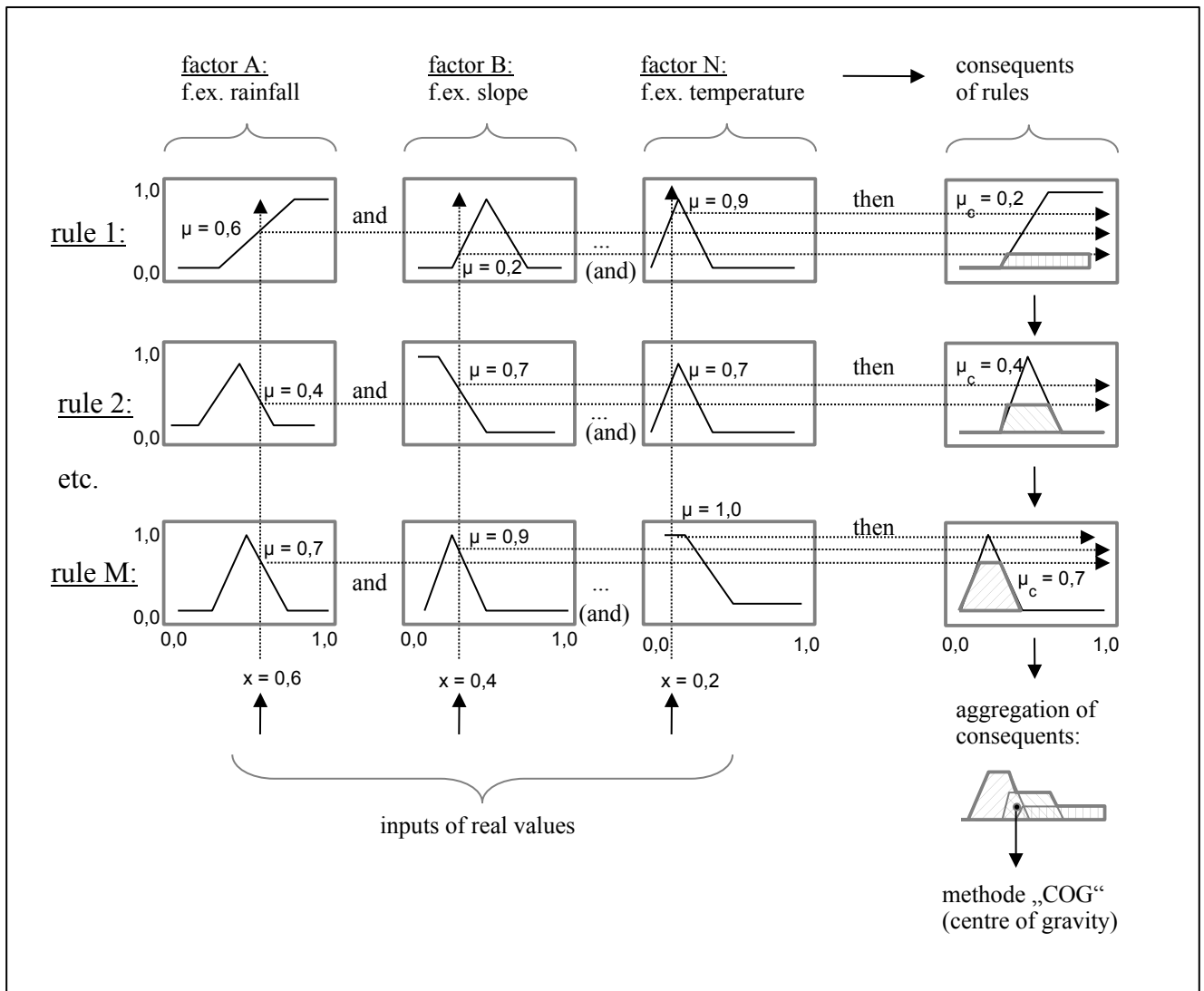

Figure 5. Fuzzy system process of scenarios

The values and relations in this example do not correspond with real case, they are used for illustrative purpose only. On the other hand, the reality-based scenarios should be created in such a way, so they cover most of the important situation. They have to describe the possible real combinations of factors, for example:

- The temperatures oscillate around zero AND the soil is heavily soaked by water AND the angle of the slope is between 10 and 20 degree AND ... THEN the risk of surface erosion is very high
- The temperatures are very high over more weeks AND the soil is very dry AND the ability to soak is very low AND the covering by vegetation is very poor AND the rainfall should be very heavy AND ... THEN the risk of flooding is very high; etc.

The system should be used by different types of customers with different interests and points of view. Thus, we have to assign critical scenarios to each of these categories of customers or users of the area.

### 3.8 Recalibration

The whole system of factors incl. their limits, measured or calculated values and rules has been based on certain sets of data. That data describe actual status of input conditions and, they create a system balanced between certain limits. When the conditions changes (i.e. the limits have been stepped over because of change of any factor), it is necessary to evaluate the impact of such a change to re-calibrate the system based on new input conditions.

## 4 CONCLUSION

The method described here has been tested and implemented on model sites Lake Most and Lake Chabarovice. The information system, connected with this method, collects available data including making overview of classified information about sites, including possibility of their further processing. This system also enables to administrate the site based on both historic and newly created analysis for strategic and operating decision about technical exploration. The tested sites are characterised by complex geologic, geotechnic and hydrogeologic conditions.

The results of this work can be used over long time period due to the fact, that there will be next open-case mines closed in next years. The aim when creating the IS MARE will also be to secure its easily extension-ability also for other environmental data, which makes it possible to use also for other areas touched by human activities, such as re-cultivation, or on areas endangered by geo-hazards etc. We suppose, the users will be mostly owners and estate-keepers or authorities.

## ACKNOWLEDGEMENTS

The study is sponsored by the Project No. TA02020177 of the Technology Agency of the Czech Republic.

## REFERENCES

Sembera, J., Nechyba, M., Alföldi, K., Titl, F., 2012. Project MARE – Information systems for decision support in usage of landscapes after re-cultivation; Collection PGM (2012)